

Applications

- Water supply
- Industry pressure boosting
- Industry liquid transfer
- Water treatment
- Irrigation

Motor

- Fitted with a totally enclosed fan-cooled, 2-pole motor
- Enclosure class: IP55
- Insulation class: F
- Supply voltage: 50Hz or 60Hz

Operation conditions

- Thin, clean, non-explosive liquids, not containing solid particles or fibers liquid
- Liquid temperature: normal temperature type: -15°C~+70°C hot water type: -15°C~+105°C
- Ambient temperature: maximum +40°C
- Altitude: maximum 1000m

Material

- Inlet&outlet chamber: Cast iron/Stainless steel(304/316)
- Impeller: Stainless steel(304/316)
- Shell: Stainless steel(304/316)
- Shaft: Stainless steel(304/316)
- Coupling: Ductile iron
- Bearing: Tungsten carbide
- Mechanical seal: Tungsten carbide/Graphite

Performance Curves

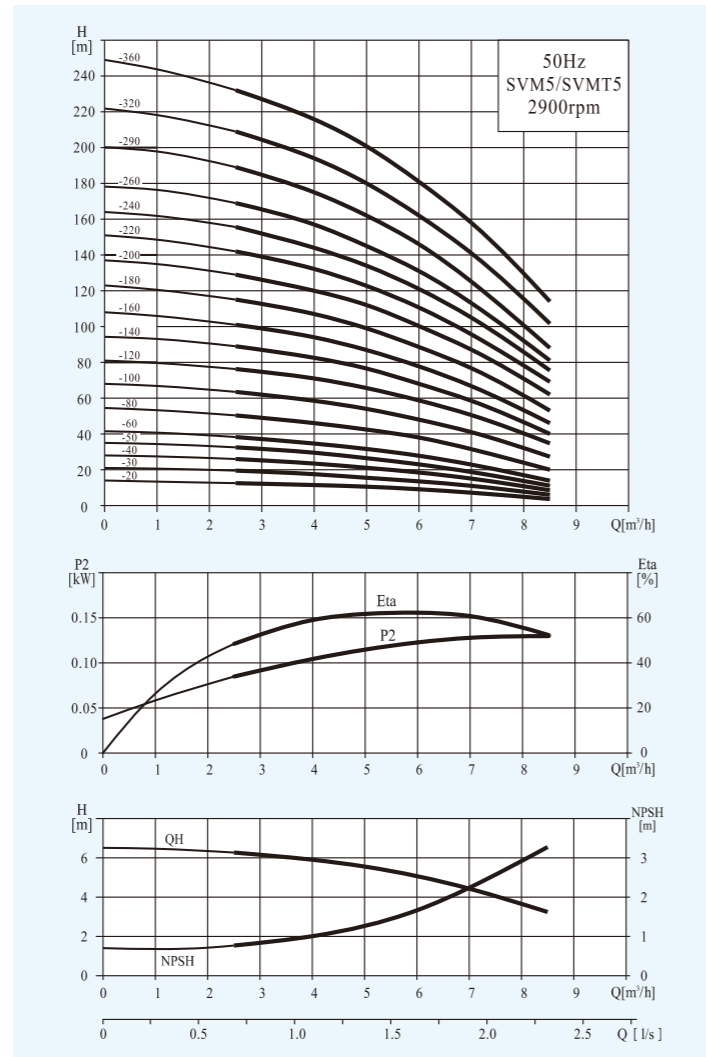

Performance Table

Model	Associated motor(kW)	Q (m³/h)	H (m)							
			2.5	4	5	6	7	8.5		
SVM5-20	0.37		12.5	11.5	10.5	9	7	3.5		
SVM5-30	0.55		19.5	17.5	15.5	13.5	11	6		
SVM5-40	0.55		26	23.5	21	18.5	15	8.5		
SVM5-50	0.75		32.5	29.5	26.5	23	18.5	11		
SVM5-60	1.1		38.5	34.5	31.5	28	23	14		
SVM5-80	1.1		50.5	46	42.5	38	31.5	20		
SVM5-100	1.5		63.5	58.5	54	48	41	27.5		
SVM5-120	2.2		76	71	65.5	58.5	50.5	35		
SVM5-140	2.2		89	82	76.5	68	58.5	40		
SVM5-160	2.2		101	94	87	77.5	66.5	46		
SVM5-180	3.0		115	107	99	88.5	77	53		
SVM5-200	3.0		129	120	112	100	87	62		
SVM5-220	4.0		142	132	123	111	96	69		
SVM5-240	4.0		156	144	134	121	105	75.5		
SVM5-260	4.0		169	157	145	131	113	81		
SVM5-290	4.0		189	175	162	146	125	88		
SVM5-320	5.5		209	194	180	162	141	102		
SVM5-360	5.5		232	216	201	181	158	114		

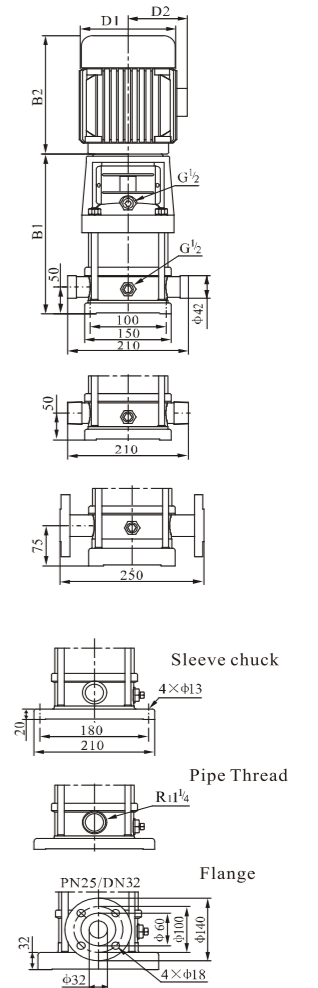

Dimension & Weight

Model	Size (mm)					Net Weight(kg)
	B1	B2	B1+B2	D1	D2	
SVM5-20	276	225	501	148	117	21
SVM5-30	303	225	528	148	117	22
SVM5-40	330	225	555	148	117	23
SVM5-50	367	245	612	170	142	25
SVM5-60	394	245	639	170	142	26
SVM5-80	448	245	693	170	142	27
SVM5-100	512	290	802	190	155	33
SVM5-120	566	290	856	190	155	37
SVM5-140	620	290	910	190	155	38
SVM5-160	674	290	964	190	155	39
SVM5-180	738	345	1083	197	165	48
SVM5-200	792	345	1137	197	165	49
SVM5-220	846	355	1201	230	185	57
SVM5-240	900	355	1255	230	185	58
SVM5-260	954	355	1309	230	185	59
SVM5-290	1035	355	1390	230	185	60
SVM5-320	1136	390	1526	260	210	75
SVM5-360	1244	390	1634	260	210	76