

Stainless Steel Vertical Multistage Pump SVM(T)10

Applications

- Water supply
- Industry pressure boosting
- Industry liquid transfer
- Water treatment
- Irrigation

Motor

- Fitted with a totally enclosed fan-cooled, 2-pole motor
- Enclosure class: IP55
- Insulation class: F
- Supply voltage: 50Hz or 60Hz

Operation conditions

- Thin, clean, non-explosive liquids, not containing solid particles or fibers liquid
- Liquid temperature: normal temperature type: -15°C~+70°C hot water type: -15°C~+105°C
- Ambient temperature: maximum +40°C
- Altitude: maximum 1000m

Material

- Inlet&outlet chamber: Cast iron/Stainless steel(304/316)
- Impeller: Stainless steel(304/316)
- Shell: Stainless steel(304/316)
- Shaft: Stainless steel(304/316)
- Coupling: Ductile iron
- Bearing: Tungsten carbide
- Mechanical seal: Tungsten carbide/Graphite

Performance Curves

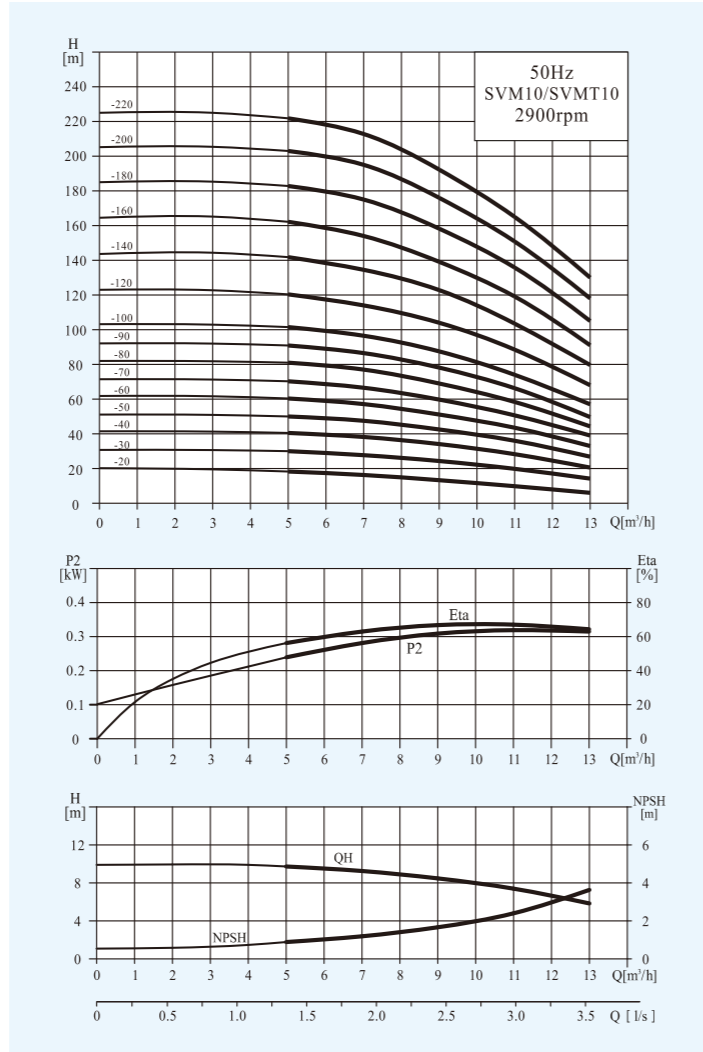

Performance Table

Model	Associated motor(kW)	Q (m³/h)	H (m)								
			5	6	7	8	9	10	11	12	13
SVM10-20	0.75		18.5	17	16	14	13	12	10	8.5	7
SVM10-30	1.1		30	28.5	27.5	25.5	24.5	22	20	18	14.5
SVM10-40	1.5		40.5	39.5	38.5	36.5	34	31.5	28.5	25.5	21
SVM10-50	2.2		50	49	47.5	45.5	42.5	39.5	36	32	27
SVM10-60	2.2		60	59	57	55	51	47.5	43.5	39	33.5
SVM10-70	3.0		70.5	69	66.5	64	59.5	55.5	50.5	45.5	39
SVM10-80	3.0		81	79	77	74.5	69	64	58.5	53	44.5
SVM10-90	3.0		91	89	86.5	82.5	78	72	66.5	59.5	50
SVM10-100	4.0		101.5	99	96.5	92.5	87.5	81.5	74	67	57
SVM10-120	4.0		120.5	119	114	110	104	97	88.5	80	68
SVM10-140	5.5		142	139	134.5	131	123	114	103.5	93.5	80
SVM10-160	5.5		162	159	154	148.5	139	130	119	107	91
SVM10-180	7.5		183	180	175	167	158	148	136	121	105
SVM10-200	7.5		203	200	195	186	176	165	151	134	118
SVM10-220	7.5		222	219	213	203	192	179	165	149	130

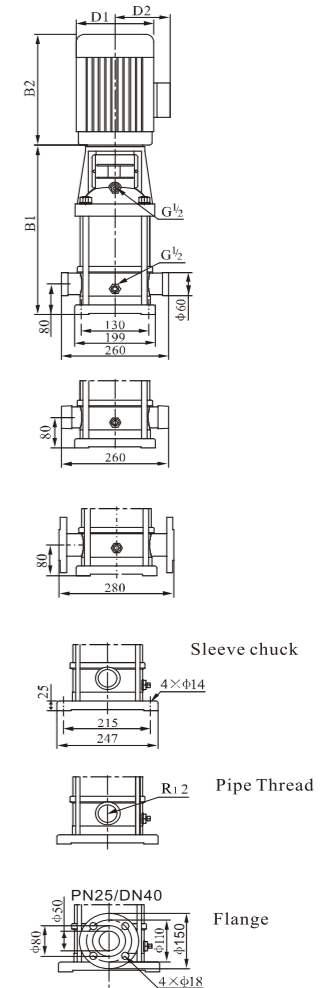

Dimension&Weight

Model	Size (mm)					Net Weight(kg)
	B1	B2	B1+B2	D1	D2	
SVM10-20	347	245	592	170	142	32
SVM10-30	377	245	722	170	142	34
SVM10-40	417	290	707	190	155	40
SVM10-50	447	290	737	190	155	44
SVM10-60	477	290	767	190	155	45
SVM10-70	517	345	862	197	165	52
SVM10-80	547	345	892	197	165	53
SVM10-90	577	345	922	197	165	54
SVM10-100	607	355	962	230	185	64
SVM10-120	667	355	1022	230	185	66
SVM10-140	747	390	1137	260	210	81
SVM10-160	807	390	1197	260	210	82
SVM10-180	867	390	1257	260	210	93
SVM10-200	927	390	1317	260	210	94
SVM10-220	987	390	1377	260	210	95